

Machine type: 10086/3109/4743 [K430]
10089/1168/4744 [K410]
10090/2556/4748 [K415]
10121/90A1 [K450 ES]
10120/90A0 [K450 Non-ES]

Lenovo

IdeaCentre K4 Series

User Guide

Version 3.0 2012.12

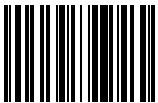

31503699



lenovo

ideacentre

Important Safety Information

Before using this manual, it is important that you read and understand all of the related safety information for this product. Refer to the *Safety and Warranty Guide* that you received with this product for the latest safety information. Reading and understanding this safety information reduces the risk of personal injury or product damage.

The interface and functions shown in this User Guide are provided for reference only and may differ from actual product appearance. Product design and specifications may be changed without notice.



Danger: Be aware of extremely hazardous or potentially lethal situations.



Attention: Be aware of possible damage to programs, devices, or data.



Note: Pay attention to this important information.

© Copyright Lenovo 2013. All rights reserved.

LIMITED AND RESTRICTED RIGHTS NOTICE: If data or software is delivered pursuant a General Services Administration “GSA” contract, use, reproduction, or disclosure is subject to restrictions set forth in Contract No. GS-35F-05925.

Contents

Important Safety Information

Using the Computer Hardware 1

- Front view of the chassis2
- Rear view of the chassis.....3
- Connecting your computer.....8
- 5.1 Audio configuration instructions.....9
- 7.1 Audio configuration instructions.....10
- Connecting the power cord..... 11
- Display connecting instructions when playing Blu-ray Discs..... 12
- Connecting to the Internet..... 12
- Wired keyboard (selected models only) 13
- Hot-swappable hard disk (selected models only) 14
- Power Control Switch (selected models only) 16

Using Windows 8 21

- Switching between the main Windows 8 interfaces22
- The Charms Bar22
- Shutting down the computer22
- Switching between apps23
- Closing an app23
- Opening other system programs23
- Windows Help and Support23

Using the Rescue System..... 25

- OneKey Recovery26
- Driver and Application Installation27

Using the Software	29
Lenovo Support	30
Troubleshooting and Confirming Setup	31
Troubleshooting Display Problems	32
Troubleshooting Audio Problems	33
Troubleshooting Software Problems	34
Troubleshooting Problems with Optical Drives and Hard Disks	34
Special considerations for troubleshooting Windows	35
Windows Help and Support	36
BIOS setup utility	36
Performing Daily Maintenance Tasks	37
Hardware Replacement Guide	39
Locations	43
Replacing hardware	48
Appendix.	61
Declaration	61
Trademarks	62
Energy Star Statement	63
Enabling ErP compliance mode.....	64

Using the Computer Hardware

This chapter contains the following topics:

- Introduction to the computer hardware
- Information on computer connections

 **Note:** The descriptions in this chapter might be different from what you see on your computer, depending on the computer model and configuration.

Front view of the chassis



Attention: Be careful not to block any air vents on the computer. Blocked air vents can cause overheating.

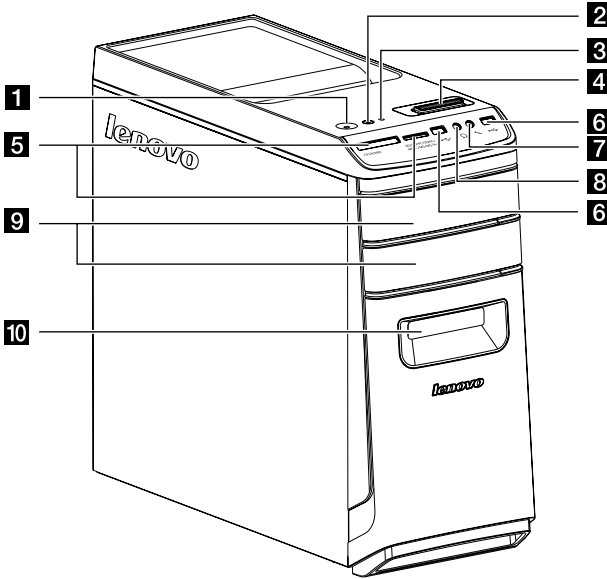

- 1** Power button
- 2** Power Control Switch indicator ON/OFF (selected models only)
- 3** Hard disk drive indicator
- 4** Power control switch (selected models only)
- 5** Memory card readers (selected models only)
- 6** USB connector/USB power off charging connector (selected models only)
- 7** Microphone connector
- 8** Headphone connector
- 9** Optical drives (some models are equipped with only one optical drive)
- 10** Hot-swappable HDD port (selected models only)



Attention: Do not insert 3-inch discs into the optical drive.

Rear view of the chassis

(If the rear view configuration shown in this chapter is different from the rear of your computer, please refer to the rear of your computer.)

IdeaCentre K450

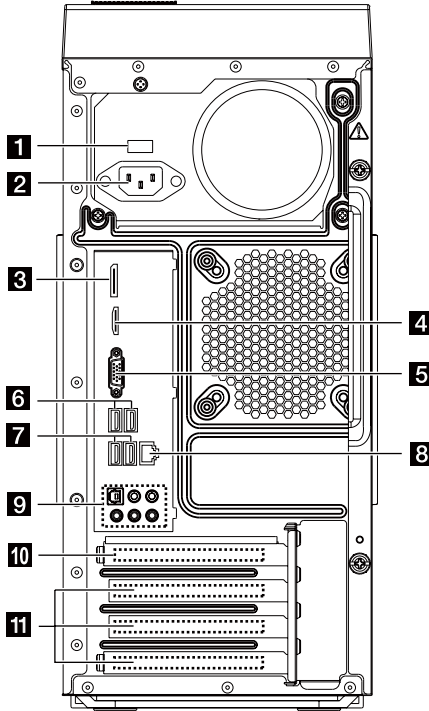

- 1** Voltage selection switch (selected models only)
- 2** Power connector
- 3** DisplayPort connector (selected models only)
- 4** HDMI connector (selected models only)
- 5** On-board VGA connector
- 6** USB 3.0 connector (selected models only)
- 7** USB 2.0 connector
- 8** Ethernet connector
- 9** Audio connectors
- 10** PCI Express X 16 graphics adapter slot (some models are equipped with a graphics card)

- 11** PCI Express X 1 adapter slots (some models are equipped with a WIFI card or TV tuner card)

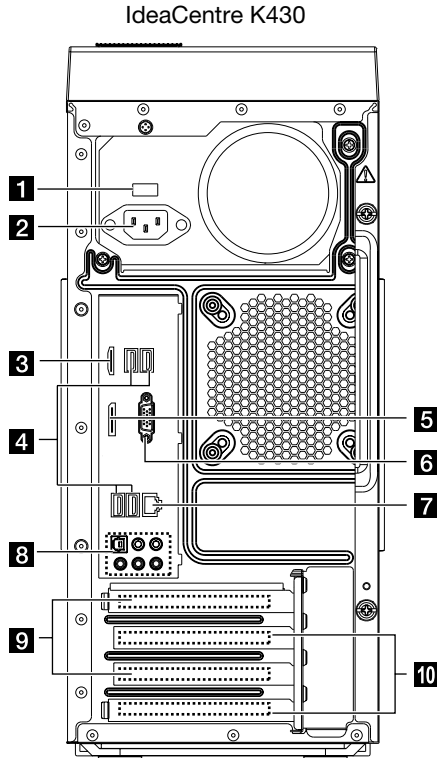

- 1** Voltage selection switch (selected models only)
- 2** Power connector
- 3** HDMI connector (selected models only)
- 4** USB connectors
- 5** DisplayPort connector (selected models only)
- 6** On-board VGA connector
- 7** Ethernet connector
- 8** Audio connectors
- 9** PCI Express X 16 graphics adapter slots (some models are equipped with a graphics card)

- 10** PCI Express X 1 adapter slots (some models are equipped with a WIFI card or TV tuner card)

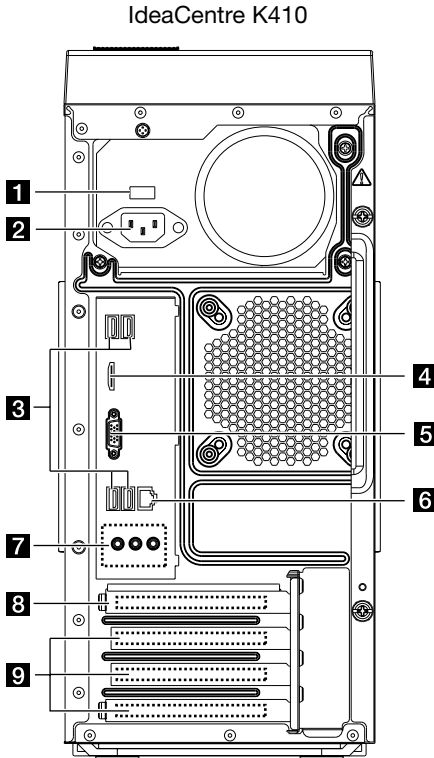

- 1** Voltage selection switch (selected models only)
- 2** Power connector
- 3** USB connectors
- 4** HDMI connector (selected models only)
- 5** On-board VGA connector
- 6** Ethernet connector
- 7** Audio connectors
- 8** PCI Express X 16 graphics adapter slot (some models are equipped with a graphics card)
- 9** PCI Express X 1 adapter slots (some models are equipped with a WIFI card or TV tuner card)

IdeaCentre K415

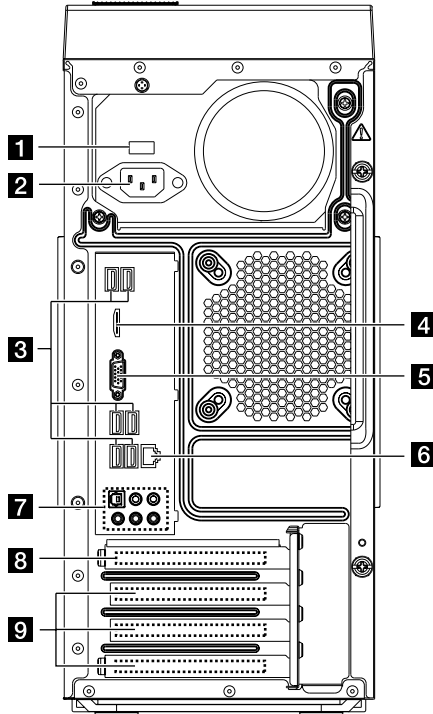

- 1** Voltage selection switch (selected models only)
- 2** Power connector
- 3** USB connectors (USB ports 4 to 6)
- 4** HDMI connector (selected models only)
- 5** On-board VGA connector
- 6** Ethernet connector
- 7** Audio connectors
- 8** PCI Express X 16 graphics adapter slot (some models are equipped with a graphics card)
- 9** PCI Express X 1 adapter slots (some models are equipped with a WIFI card or TV tuner card)

! **Note:** If your model has two VGA monitor connectors, be sure to use the connector on the graphics adapter.

Basic connector instructions

Connector	Description
Microphone	Use this connector to attach a microphone to your computer when you want to record sound or if you use speech-recognition software.
Headphone	Use this connector to attach headphones to your computer when you want to listen to music or other sounds without disturbing anyone.
Audio line-in connector	Used to receive audio signals from an external audio device, such as a stereo system. When you attach an external audio device, a cable is connected between the audio line-out connector of the device and the audio line-in connector of the computer.
Audio line-out connector	Used to send audio signals from the computer to external devices, such as powered stereo speakers (speakers with built-in amplifiers), headphones, multimedia keyboards, or the audio line-in connector on a stereo system or other external recording device.
USB connector	Use this connector to attach a device that requires a USB connection.
Ethernet connector	Use this connector to attach the computer to an Ethernet-type local area network.
VGA connector	Used to attach a VGA monitor or other devices that use a VGA monitor connector.
DVI connector	Used to attach a DVI monitor or other devices that use a DVI monitor connector.
HDMI connector (optional)	Connects to the HDMI connector on your display or TV.
DisplayPort connector (optional)	Used to attach a high-performance monitor, a direct-drive monitor, or other devices that use a DisplayPort connector.
TV-Tuner connector (optional)	Only supported on systems with an optional TV tuner card.

 **Note:** If your computer is equipped with a wireless keyboard or mouse, follow the installation instructions for those devices.

Connecting your computer

! **Note:** Your computer may not have all of the connectors described in this section.

Check the position of the voltage-selection switch on the rear of the computer. Use a ballpoint pen to slide the switch if necessary.

! **Note:** Some computers do not have a voltage switch. These computers control voltage automatically.

- If the voltage supply range is 100-127 V AC, set the switch to 115 V.
- If the voltage supply range is 200-240 V AC, set the switch to 230 V.

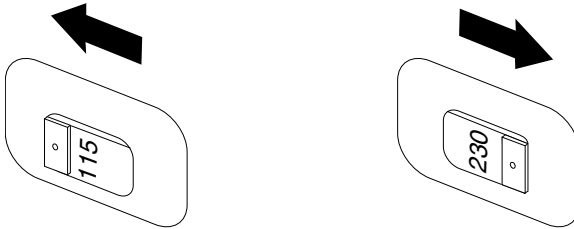

5.1 Audio configuration instructions

This model of computer supports the transformation of stereo sound into 5.1 surround sound.

Use the following guides when connecting to the 5.1 surround audio device:

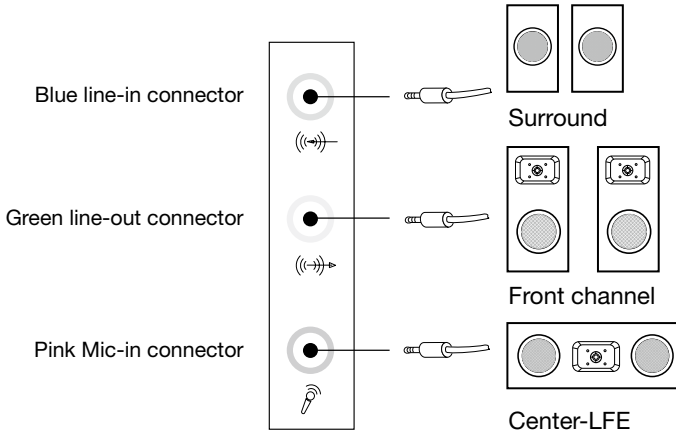

The configurations are as followings:

1. Right click the **Sound** icon in system property bar and select **Sounds** option to setup the sounds in the pop-up dialog box.
2. Select a playback device from the **Playback** dialog box, then click the **Configure** button to configure it.
3. Select **5.1 surround** from audio channels in the pop-up **Speaker setup** dialog box to proceed with the speaker setup by following the prompts.
4. 5.1 surround sound can be used once this configuration procedure is complete.

Note: If the audio configuration interfaces above are different from those on your computer, you may use the above steps as a reference to configure the 5.1 surround sound audio device system in your actual audio configuration interface and read the electronic Help information for further assistance.

7.1 Audio configuration instructions

Use the following illustration when connecting a 7.1 surround sound audio system

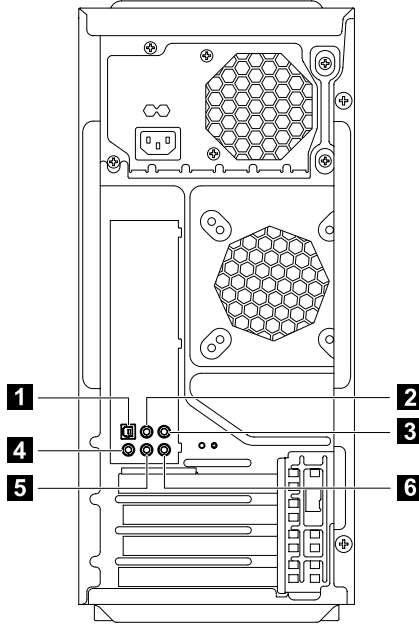

- | | |
|--|-------------------------------------|
| 1 S/PDIF out connector | 4 Microphone input Connector |
| 2 Center / Low frequency output connector | 5 Audio line-out Connector |
| 3 Surround out connector | 6 Audio line-in Connector |

! **Note:** For more detailed settings, from **Control panel**, select **Hardware and Sound** → **Lenovo HD Audio Manager**. Follow the instructions to configure advanced settings.

Sound configuration is as follows:

1. Right click the **Sound** icon in the system property bar and select the **Sounds** option to set up sounds in the pop-up dialog box.
2. Select a playback device from the **Playback** dialog box, then click the **Configure** button to configure it.

3. Select **7.1 surround** from audio channels in the pop-up **Speaker setup** dialog box and proceed with the speaker setup by following the prompts.
4. 7.1 surround sound can be used once this configuration procedure is complete.

! **Note:** If the audio configuration interfaces above are different from those on your computer, you may use the above steps as a reference to configure the 7.1 surround sound audio device system in your actual audio configuration interface and read the electronic Help information for further assistance.

Connecting the power cord

Connect the power cord to an electrical outlet. We recommend using a grounded connection or a surge protector.

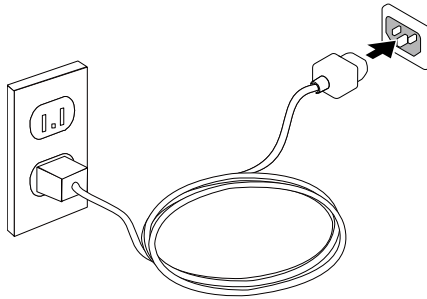







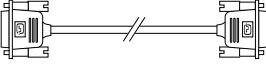

Display connecting instructions when playing Blu-ray Discs

! **Note:** Only some models are equipped with Blu-ray optical drive.

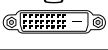
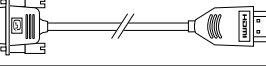
Check the connectors available on your computer and display and select an appropriate cable according to the table below. Other types of cables do not meet the requirements of the Blu-ray standard.

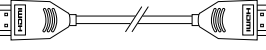
You need to purchase the cable separately if the computer is not equipped with the corresponding cable.

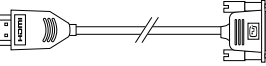
This table will help you to identify the connectors on your computer and display.

Connection Type	Computer	Cable	Display
DVI to DVI (DVI cable)			
DVI to HDMI (DVI-HDMI cable)			
HDMI to HDMI (HDMI cable)			
HDMI to DVI (HDMI-DVI cable)			

Connecting to the Internet

To connect to the Internet, you'll need a contract with an Internet Service Provider (ISP) and some hardware.

IPs and ISP offerings vary by country. Contact your ISP for offerings available in your country.

Your computer is designed to support a wireless (selected models only) or wired network that connects your computer to other devices.

Wired network connection

For wired networks, connect one end of an Ethernet cable (purchased separately) to the Ethernet connector on your computer, and then connect the other end to the network router or broadband modem. Consult your ISP for detailed setup instructions.

! **Note:** Broadband modem and router installation procedures vary depending on the manufacturer. Follow the manufacturer's instructions.

Wireless network connection

For wireless networks, you can use the built-in wireless LAN antenna to access your wireless home network.

To connect your computer to the wireless network:

1. Move the cursor to the top right or bottom right corner of the screen, then click **Settings**. (If your computer is equipped with touch screen, swipe in from the right edge of the screen, then tap **Settings**.)
2. Click or tap the network icon , then select the name of your router. Click or tap **Connect**, then follow the steps on the screen.

Test the wireless network by opening your Web browser and accessing any Web site.

Wired keyboard (selected models only)

LVT — After entering Windows, press this key to launch the LVT (Lenovo Vantage Technology) program, Lenovo's pre-loaded Home PC software. In addition to its own functions, the LVT program will allow you to start other Windows compatible software specially configured to run on this model of computer.

Notes:

- Some models are not equipped with the LVT program.
- The LVT key on the keyboard is disabled in the models without the LVT program.

F2 — Your computer has the Lenovo Rescue System installed. To learn more about this program, repeatedly press and release the F2 key once turning on the computer until the Lenovo Rescue System opens.

Hot-swappable hard disk (selected models only)

- Components

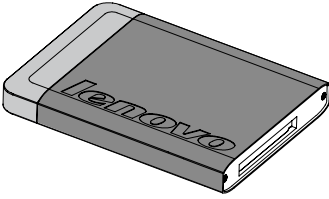

Hot-swappable hard disk

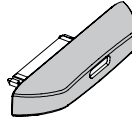

USB adapter

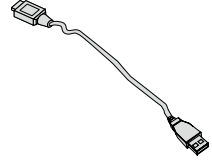

USB cable

You can plug in the hot-swappable hard disk while the computer system using it is working, without damaging the hard disk data. You can back up the data on this hot-swappable hard disk at any time for data maintenance or data transmission.

- Using the hot-swappable hard disk

Method 1: Slide it into the bay from the front until it clicks into position.

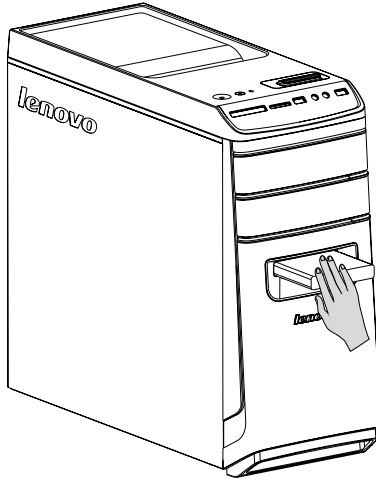

Method 2: Pull the hot-swappable hard disk drive out of the drive bay, then connect the hot-swappable hard disk drive to the other computer.

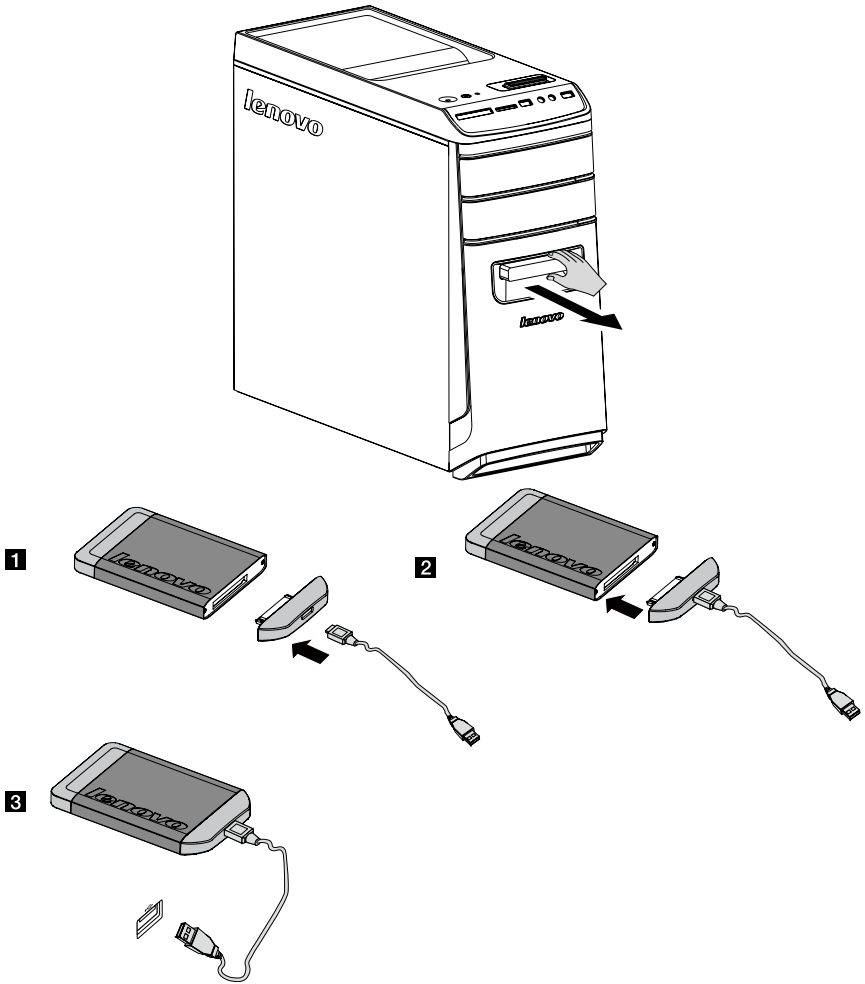

! Notes:

- Do not unplug the hard disk while it is copying data, as this may result in loss of data.
- After connecting the hard disk and all the cables, wait a moment to allow the system to recognise the hard disk.
- Do not install the operating system on the hot-swappable hard disk.
- Do not unplug the hard disk while it is running a program, as this may result in the system crashing.

- After removing the hard disk, be careful not to damage it.
- In the Rescue System program, the hot-swappable hard disk can not be recognised.

Power Control Switch (selected models only)

The Power Control Switch feature allows your computer to switch to different modes, thus providing you with customized experiences during operations.

Operation of the Power Control Switch

The Power Control Switch function supports three operating modes: **Auto**, **Turbo** and **Cool**. You can optimize system resources by toggling between those three different modes. Different modes are used for different applications. In **Auto** and **Cool** mode, computer will boot up quickly; in **Turbo** mode, computer will boot up very quickly.

- Switch to a different mode by toggling the power control switch.

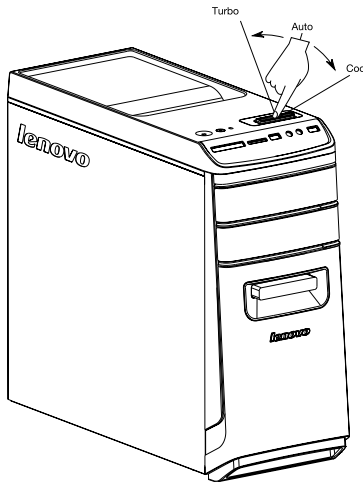

- Press the Power Control Switch indicator **ON/OFF** button to open the indicator under the front panel and set the different lighting effects in each mode.



- To display the main screen of the software

Double click the **Power Control Switch** icon from the Start charm or the Desktop.



Open the running status for each component under the Mode Switch:

CPU — Show the percentage of the current CPU clock frequency against the nominal maximal CPU clock frequency.

Boot — The status of the computer startup speed.

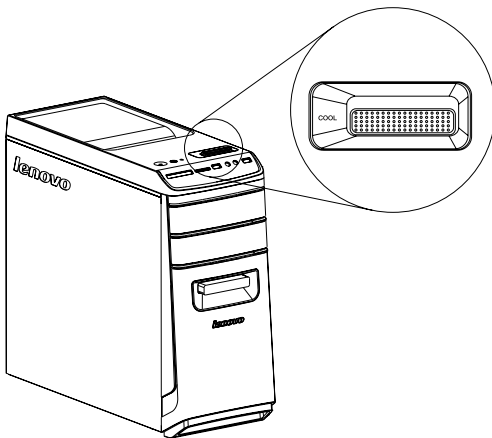
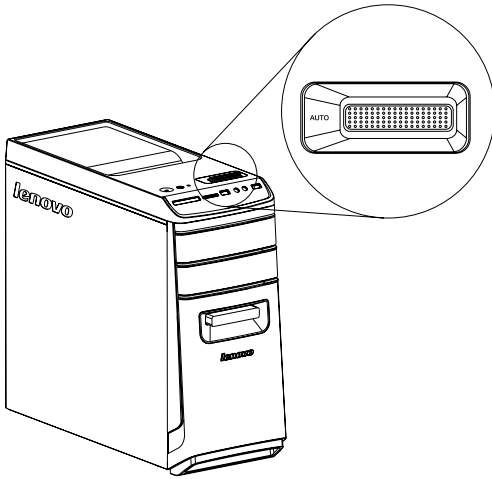

AUTO

Auto adjust the system CPU clock frequency and running speed. Toggle the Power Control Switch to the Auto position to enable this mode.

Note:

The numeric values may vary because each model is configured differently.

COOL

The CPU runs at low frequency. The system consumes minimum power. Toggle the Power Control Switch to the Cool position to enable this mode.

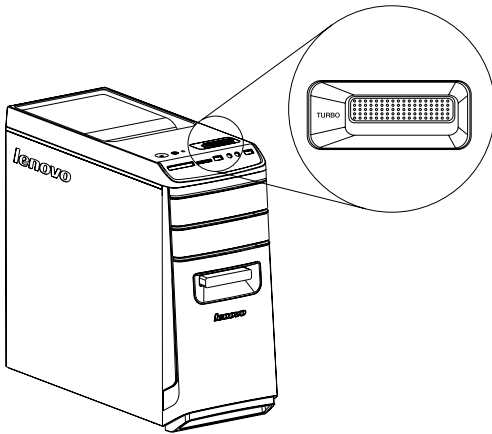

Note:

The numeric values may vary because each model is configured differently.

TURBO

The CPU runs at full speed. The system achieves its optimal performance. Toggle the Power Control Switch to the Turbo position to enable this mode.

Note:

The numeric values may vary because each model is configured differently.



Notes:

- When you are running system-intensive games or other programs that consume a high proportion of the system resources, you should choose Turbo mode. This will allow you to achieve optimal performance.
- After unplugging and reconnecting the power cord to the outlet, the computer cannot boot up at ultra speed in Turbo mode. In order to keep ultra speed during the boot up, the computer must always keep connecting the outlet.
- Toggle the Power Control Switch to the Auto or Boot position when using **OneKey Recovery** program.

Using Windows 8

This chapter contains the following topics:

- Switching between the main Windows 8 interfaces
- The Charms Bar
- Shutting down the computer
- Switching between apps
- Closing an app
- Opening other system programs
- Windows Help and Support



Attention: The Windows 8 operating system is provided by Microsoft Corporation. Please use it in accordance with the END USER LICENSE AGREEMENT (EULA) between you and Microsoft. For any question related to the operating system, please contact Microsoft directly.

Switching between the main Windows 8 interfaces

Windows 8 comes with two main user interfaces: the Start Screen and the Windows desktop.

To switch from the Start Screen to the Windows desktop, do one of the following:

- Select the Windows desktop tile on the Start Screen.
- Press the Windows key  + D.

To switch from the desktop to the Start Screen, do one of the following:

- Select **Start** from the Charms Bar.
- Move the cursor to the bottom left corner, then select the Start Screen thumbnail when it is displayed.
- Press the Windows key .

The Charms Bar

Charms provide new and faster ways to perform many basic tasks.

To display the charms, do one of the following:

- Move the cursor to the top right or bottom right corner of the screen.
- If your computer is equipped with touch screen, swipe in from the right edge of the screen.
- Press the Windows key  + C.

Shutting down the computer

To shut down the computer:

1. Move the cursor to the top right or bottom right corner of the screen, then click **Settings**. (If your computer is equipped with touch screen, swipe in from the right edge of the screen, then tap **Settings**.)
2. Select **Power** → **Shutdown**.

Switching between apps

Sometimes you want to get back to an app you were just using, or quickly switch through your recent apps.

To switch between apps:

Move the cursor to the top left corner, then click to bring in the next app. (If your computer is equipped with touch screen, swipe in from the left edge of the screen to bring in the next app.)

Closing an app

To close an app, do one of the following:

- Move the cursor to the top left corner of the screen. When the thumbnail appears, drag it to the bottom of the screen.
- Move the cursor to the top edge of the screen. When the cursor becomes a hand, drag the app page to the bottom of the screen.
- If your computer is equipped with touch screen, swipe in from the top edge of the screen. When the app page becomes smaller, drag it to the bottom of the screen.

Opening other system programs

There is a fast way to open other system programs.

To open the menu, do one of the following:

- Move the cursor to the bottom left corner of the screen. When the thumbnail appears, right-click with the mouse to open the menu.
- Press the Windows key  + X.

Windows Help and Support

If you have a problem with the operating system, see the Windows Help and Support file. To open the Windows Help and Support file, do one of the following:

- Select the **Settings** charm, then select **Help**.
- Press the Windows key  + F1.

You can read the Windows Help and Support file on your computer. You can also get online help and support by clicking on one of the two links listed under **More to explore**.

Using the Rescue System

This chapter contains the following topics:

- OneKey Recovery
- Driver and Application Installation



Attention: Using OneKey Recovery will result in loss of data.

- You can restore the C: drive of the computer to factory default settings or to the last system backup status using **OneKey Recovery**. If you do this, all of the existing data on drive C: will be lost, but the content and format of the other partitions of the hard disk drive will remain unchanged.
- If you want to install an operating system and back it up with **OneKey Recovery**, you must format the C: partition in **NTFS** format and install the operating system on the C: partition. Otherwise, the **OneKey Recovery** system cannot run.

Note about the service partition:

The files and relevant data used by the rescue system are saved in the service partition. Deleting this partition will make the rescue system unusable. For more detailed information, see the following instructions:

From the **Search** charm, select **Apps** → **Control Panel** → **Administrative Tools** → **Computer Management** → **Disk Management**, you can see the service partition, which must not be deleted.

 **Note:** The recovery files and relevant data used by the rescue system are saved in the service partition. If the service partition is deleted or damaged by someone other than authorized Lenovo service personnel, Lenovo will not be liable for any losses arising therefrom in any way.

OneKey Recovery

OneKey Recovery is an easy-to-use application. You can use it to restore your computer to the system default or to a previously backed up state.

Detailed Operation Procedure

1. Repeatedly press and release the **F2** key once turning on the computer until the **Lenovo Rescue System** opens, then select **OneKey Recovery**.

 **Note:** System Recovery will overwrite all of the data on the C: drive. To prevent loss of data, be sure to back up relevant data before performing system recovery.

2. Follow the on-screen instructions to select the backup task you want to restore from and the disk where you want to install the operating system, then press **Next** to start the restore.
3. Please wait during the process of system recovery. Do not interrupt the operation during the recovery process.
4. After the system is recovered successfully, the software will prompt you to restart the computer. Restart the computer and start the operating system.

Driver and Application Installation

The **Driver and Application Installation** function in the rescue system provides a way for the user to conveniently reinstall all of the Lenovo applications and drivers that were shipped with your Lenovo hardware.

Method 1: Automatic Installation

Repeatedly press and release the **F2** key once turning on the computer until the **Lenovo Rescue System** opens, then select **Drivers and Application Installation**.

Follow the on-screen prompts to install the Lenovo drivers and applications. Click **OK** to start installing the **Lenovo Drivers and Application Installation** software.

The system will restart. After the system has restarted, the drivers and application installation process will continue until it has completed.

Method 2: Manual Installation

In the Windows system, Select **Driver and Application Installation** from the **Search** charm.

After starting the procedure, install the drivers and software manually by following the prompts.

Notes:

1. Do not install software which is already installed on the computer.
2. Make sure that the Drivers and Application Installation software has been automatically installed before starting the operating system. The manual installation function can only be used after the software has been installed.

Using the Software



This chapter contains the following topic:

- Software instructions

 **Note:** The interface and functionality of these features will depend on which software was shipped with the computer model you purchased.

Lenovo Support

The Lenovo Support program enables you to register your computer with Lenovo, download and view user manuals for your computer, get the warranty information of your computer, and explore help and support information.

To open this program, do the following:

Click the Lenovo Support icon from the Start Screen or Search Screen.

The main functions of this program are listed below. (This program supports online upgrades. The functions shown below are for reference only, functionality will depend on the program icons currently displayed.)

Registration

Registration provides you with access to product support, upgrades and alerts on topics. Take advantage of award-winning Lenovo services.

User Guide

The User Guide provides more information about your computer.

Service and Warranty

You can extend the warranty of your computer through this option. Lenovo provides flexible options to meet your personal or business needs.

Troubleshooting and Confirming Setup

A graphic of a spiral-bound notebook with a white cover and a silver spiral binding on the left side. The notebook is open to a page with a white background and a thin black border. The text is printed on this page.

This chapter contains the following topic:

- Troubleshooting and Problem Resolution

Solving Problems

Follow these tips when troubleshooting your computer:

- If you added or removed a part before the problem started, review the installation procedures to ensure that the part is correctly installed.
- If a peripheral device does not work, ensure that the device is properly connected.
- If an error message appears on the screen, write down the exact message. This message may help support personnel diagnose and fix the problem(s).
- If an error message occurs in a program, see the Help document of this program.

Troubleshooting Display Problems

Problem: Blank screen or no image is displayed on the monitor.

Troubleshooting and problem resolution:

1. Check to see if the monitor has been turned on; if not, press the Power button.
2. Check to see if the monitor power cord is loose; if so, plug the power cord securely into the monitor.
3. Check to see if the signal cable to the monitor is securely connected to the connector on the computer graphics card; if not, shut down the computer then connect the signal cable of the monitor securely to the connector on the computer graphics card.

Problem: You need to change the display property settings.

Setting display background and icon properties:

1. Right-click the desktop anywhere except over an icon, then select Personalize from the pop-up menu.
2. From here, select the appropriate options to:
 - Change the desktop background
 - Select a screen saver
 - Select Windows color options for borders and taskbar
 - Select a themes
3. Right-click the desktop anywhere except over an icon, then select Screen resolution from the pop-up menu to change the appearance.

Problem: Ripple on screen.

Troubleshooting and problem resolution:

1. Check to see if any of the following devices are located less than one meter from the computer: refrigerators, electric fans, electric dryers, UPS systems, regulators, fluorescent lamps or other computers that may be generating magnetic interference.
2. Move any interfering devices away from the computer.
3. If the problem persists, contact Lenovo Service.

Troubleshooting Audio Problems

Problem: No sound from the integrated speakers.

Troubleshooting and problem resolution:

- Adjust the Windows volume control — select the speaker icon from the **Settings** Charm or click the arrow on taskbar to show the hidden icons in Windows desktop mode, then click the speaker icon. Ensure that the volume is turned up and the sound is not muted. Adjust the volume, bass, or treble controls to eliminate distortion.
- Reinstall the audio driver.
- Disconnect any headphones from the headphone connector — sound from the speakers is automatically disabled when headphones are connected to the computer's side-panel headphone connector.

Problem: No sound from headphones.

Troubleshooting and problem resolution:

- Check the headphone cable connection — ensure that the headphone cable is securely inserted into the headphone connector.
- Adjust the Windows volume control — select the speaker icon from the **Settings** Charm or click the arrow on taskbar to show the hidden icons in Windows desktop mode, then click the speaker icon. Ensure that the volume is turned up and the sound is not muted.

Troubleshooting Software Problems

Problem: You are unable to exit a running program normally.

Troubleshooting and problem resolution:

1. Press the **Ctrl**, **Alt** and **Delete** keys at the same time, then select the **Task Manager** option from the pop-up dialog box.
2. Select the problem program, then click the **End Task** button.

Problem: You need to install or uninstall a program.

Problem resolution:

During installation never abort the install process by powering the system off or through other drastic means. This can cause system program problems or even failure during system initialization.

During the uninstall process, never directly delete the files or folders. This is harmful to the operating system, and might cause a system-wide malfunction. Use the following procedure to properly uninstall programs:

1. Back up all documents and system settings related to the program before removing it.
2. If the program has its own uninstaller, run it directly to uninstall the program.
3. If the program does not have its own uninstaller, then select **Apps** → **Control Panel** from the **Search** charm.
4. From the **Control Panel**, choose **Programs** → **Programs and Features**.
5. Find the applicable program from the **Programs and Features** dialog box and then select **Uninstall/Change**.
6. Perform the instructions displayed to uninstall the software.

Troubleshooting Problems with Optical Drives and Hard Disks

Problem: The Optical drive is unable to read a CD/DVD.

Troubleshooting and problem resolution:

1. Check to determine if there is an optical drive icon in the resource manager of the operating system. If not, restart your computer. If there is still no icon, contact Lenovo Service. Otherwise, continue with the next step of this procedure.

2. Confirm that the CD/DVD has been properly placed in the drive. If not, reload the CD or DVD. Otherwise, continue with the next step of this procedure.
3. Check the specifications that came with your computer to confirm that this optical drive is capable of reading this type of CD or DVD.
4. If the CD/DVD cannot be read, replace it with a known good CD/DVD such as one that was shipped with the computer.
5. If the known good CD cannot be read, visually check the operating side of the CD/DVD for defects.

Problem: The capacity of the hard disk, as indicated by the system, is less than the nominal capacity.

Troubleshooting and problem resolution: For computers equipped with the OneKey Recovery feature, the system recovery feature needs to occupy some hard disk space. This may account for the apparent hard disk capacity deficit.

Further Technical Explanation: The nominal capacity of the hard disk is expressed in the decimal system as 1000 bytes. But the actual hard disk capacity is expressed in the binary system as 1024 bytes (For example, the nominal capacity 1G is 1000M, while the actual capacity 1G is 1024M).

The capacity of the hard disk shown in Windows can be calculated according to the calculations in the following example:

The nominal capacity of the hard disk is 40G, while its actual capacity should be: $40 \times 1000 \times 1000 \times 1000 / (1024 \times 1024 \times 1024) = 37G$.

If the Service partition of 3G - $3 \times 1000 \times 1000 \times 1000 / (1024 \times 1024 \times 1024) = 2.79G$ is subtracted, the capacity of the hard disk shown in the system can be obtained.

The capacity of the hard disk as calculated using this method may be slightly different from the actual capacity due to the rounding of totals.

Special considerations for troubleshooting Windows

Record the following information as it may be useful later when troubleshooting system problems:

The drivers for this computer model only support the Windows 8 system.

Windows Help and Support

If you have a problem with the operating system, see the Windows Help and Support file. To open the Windows Help and Support file, do one of the following:

- Select the **Settings** charm, then select **Help**.
- Press Windows key  + F1.

You can read the Windows Help and Support file on your computer. You can also get online help and support by clicking on one of the two links listed under **More to explore**.

BIOS setup utility

What is the BIOS setup utility?

The BIOS setup utility is ROM-based software. It communicates basic computer information and provides options for setting boot devices, security, hardware mode, and other preferences.

How can I start the BIOS setup utility?

To start the BIOS setup utility:

1. Shut down the computer.
2. Repeatedly press and release the F1 key once turning on the computer to start the Setup Utility program.

How can I change the boot mode?

There are two boot modes: UEFI and Legacy. To change the boot mode, start the BIOS setup utility and select **Startup** → **Boot Priority**, then set boot mode to UEFI or Legacy support on the boot menu.

When do I need to change the boot mode?

The default boot mode for your computer is the UEFI mode. If you need to install a legacy Windows operating system (any operating system before Windows 8) on your computer, you must change the boot mode to Legacy support. The legacy Windows operating system cannot be installed if you don't change the boot mode.

Performing Daily Maintenance Tasks

Cleaning the computer components

Because many of the computer components consist of sophisticated integrated circuit boards, it is very important to periodically clean the computer to prevent dust buildup. The cleaning supplies you need to clean the components include: a vacuum cleaner, a soft cotton cloth, pure water (preferably purified or distilled water) and cotton swabs.



Attention: Before you clean your computer, disconnect the computer from the electrical outlet. Clean your computer with a soft cloth dampened with water. Do not use liquid or aerosol cleaners, which may contain flammable substances.



Note: To avoid damaging the computer or display, do not spray cleaning solution directly onto the display. Only use products specifically designed for cleaning displays, and follow the instructions included with the product.

The following are general methods for cleaning the components:

- You can use a soft cloth to remove dust on the surface of the computer, the monitor, the printer, the speakers and the mouse.
- You can use a vacuum cleaner to clean in otherwise inaccessible corners.
- To clean the keyboard thoroughly, shut down the computer and scrub it gently with a wet cloth. Do not use the keyboard until it is dry.

Do not do any of the following:

- Allow water to enter the computer.
- Use a heavily dampened cloth.
- Spray water directly onto the surface of the monitor or inside the computer.

LCD monitor should be cleaned daily. Use a dry cloth to brush dust from the monitor and keyboard every day. Keep all surfaces clean and free of grease stains.

Hardware Replacement Guide



This chapter contains the following topics:

- Identifying internal components
- Identifying parts on the system board
- Removing the computer cover
- Removing the front bezel
- Replacing a memory module
- Replacing a hard disk drive
- Replacing an optical drive
- Replacing a graphics card
- Replacing the TV-Tuner card
- Replacing the keyboard and mouse

Overview

This guide is intended to be used by customers who are replacing Customer Replaceable Units (CRUs) as well as trained service personnel who are replacing Field Replaceable Units (FRUs). In this guide, CRUs and FRUs will often be referred to as parts.

 **Note:** Trained service personnel should refer to the *Hardware Maintenance Manual (HMM)* for parts ordering information.

This guide does not include procedures for the replacement of all parts. It is expected that trained service personnel are already able to replace cables, switches, and certain mechanical parts without the need for step-by-step procedures.

 **Note:** Use only parts provided by Lenovo®.

The description of the TV-Tuner card in this manual applies only to computer models with a TV-Tuner card, and therefore does not apply to models without a TV-Tuner card.

This guide contains instructions for replacing the following parts:

- Memory modules
- Hard disk drive
- Optical disk drive
- Graphics card
- TV-Tuner card

Safety information for replacing CRUs

Do not open your computer or attempt any repairs before reading the “Important safety information” in the *Safety and Warranty Guide* that was included with your computer. An electronic copy of the *Safety and Warranty Guide* can also be obtained online from the Lenovo® Support Web site at: <http://support.lenovo.com>.

Additional information resources

The most up-to-date information for your computer is available online at: <http://support.lenovo.com>.

You can find the following information:

- Customer replacement unit removal and installation information
- Publications
- Troubleshooting information
- Parts information
- Links to other useful sources of information

Tools required

To disassemble the computer, you will need the following tools:

- Wrist grounding strap and conductive mat for preventing electrostatic discharge
- Flat screwdriver
- Phillips screwdriver
- Hex screwdriver
- Plastic flat screwdriver
- Plastic tweezers



Note: The screws used for the different components vary in size. During the disassembly procedure, group the screws with their corresponding components to avoid a mismatch when replacing the components.

Handling static-sensitive devices

Static electricity, although harmless to you, can seriously damage computer components.

When replacing a part, do not open the anti-static packaging containing the new part until the defective part has been removed from the computer and you are ready to install the new part.

When handling parts and other computer components, the following precautions should be taken in order to avoid static electricity damage:

- Limit your movements, as movement can cause the build-up of static electricity.
- Always handle parts and other computer components with care, and handle adapters, memory modules, system boards, and microprocessors by their edges. Never touch any exposed circuitry.
- Prevent others from touching parts and other computer components.
- Before replacing a new part, first place the anti-static packaging containing the part against a metal expansion slot cover or other unpainted metal surface on the computer for at least two seconds. This will reduce static electricity in the package and your body.
- When possible, remove the new part from its anti-static packaging and install it directly into the computer without setting the part down. If this is not possible, place the part on top of its anti-static packaging on a smooth, flat surface before installing it.
- Do not place parts on the computer cover or other metal surface.

Locations

Identifying internal components

The following illustration shows the components inside your computer.

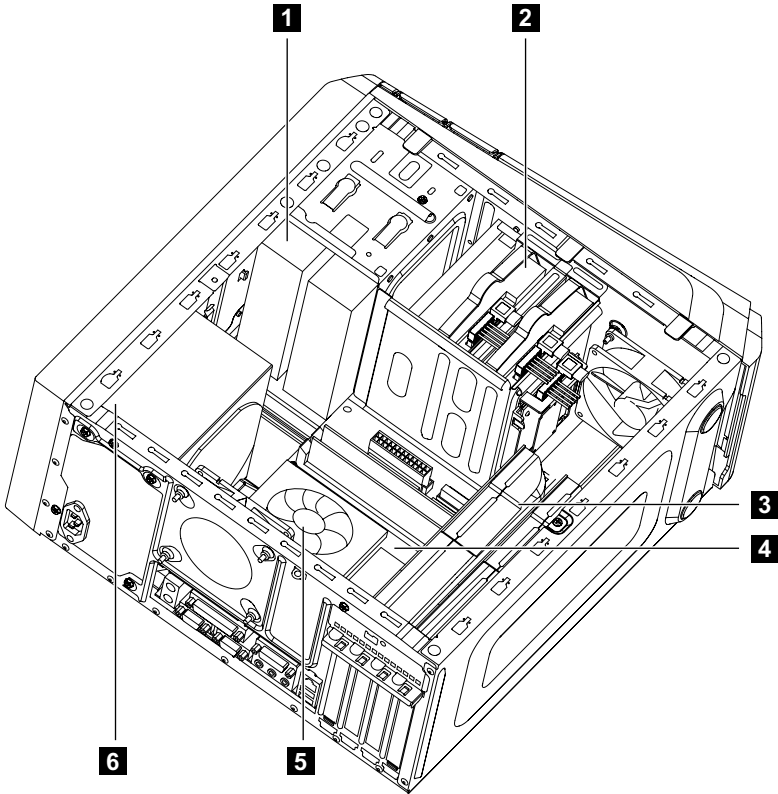

1 Optical disk drive

3 Graphics card

5 System fan

2 Hard disk drive

4 System board

6 Power supply

Identifying parts on the system board

The system board (also known as the “mainboard” or “motherboard”) is the main circuit board in your computer. It provides basic computer functions and supports a variety of devices that are factory-installed or that you can install later.

The following illustrations show the locations of the different parts on the system board.

Lenovo K450

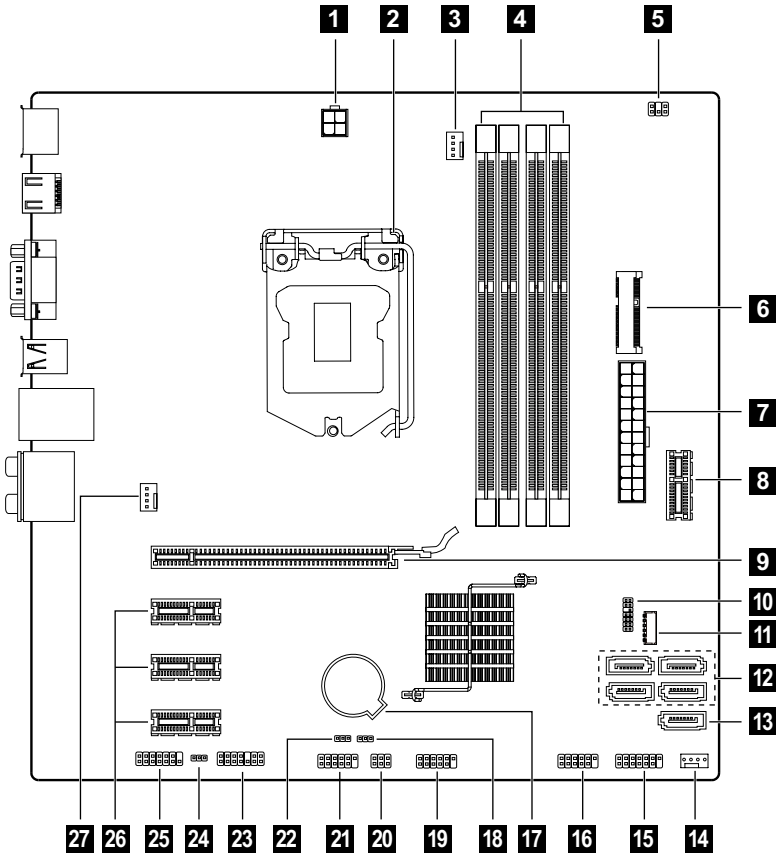

- 1** 12V power connector
- 2** Microprocessor and heat sink
- 3** Microprocessor fan header
- 4** Memory slots (4)
- 5** Thermal sensor header
- 6** Mini PCI-E slot
- 7** Power connector
- 8** Front USB slot

- | | |
|--|---|
| 9 PCI express X 16 adapter slot | 10 SPI debug connector |
| 11 Solid state disk power connector | 12 SATA connectors (4) |
| 13 eSATA connector | 14 Power fan header |
| 15 Front panel connector | 16 Front USB 2.0 connector |
| 17 Battery | 18 Clear CMOS jumper |
| 19 Front USB 3.0 connector | 20 Mode switch connector |
| 21 Serial (COM2) connector | 22 ME disable jumper |
| 23 LPC debug connector | 24 Clear CMOS jumper |
| 25 Front audio connector | 26 PCI express X 1 adapter slots (3) |
| 27 System fan header | |

Lenovo K430

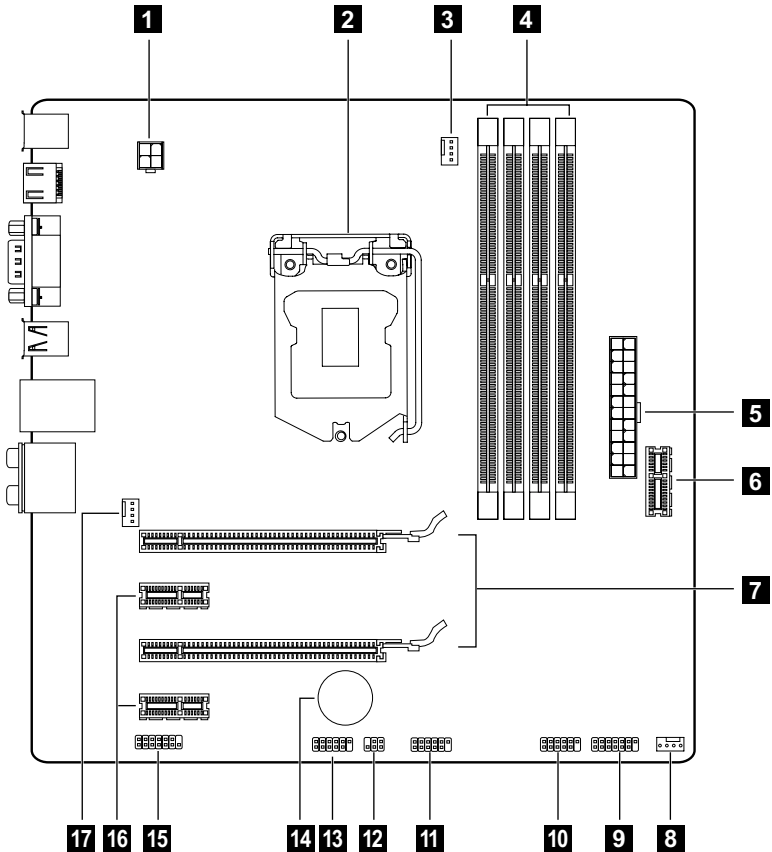

- | | |
|---|---|
| 1 12V power connector | 2 Microprocessor and heat sink |
| 3 Microprocessor fan header | 4 Memory slots (4) |
| 5 Power connector | 6 Front USB header |
| 7 PCI express X 16 adapter slots (2) | 8 Power fan header |
| 9 Front panel connector | 10 Front USB connector |
| 11 Front USB connector | 12 Mode switch connector |
| 13 Serial (COM2) connector | 14 Battery |
| 15 Front audio connector | 16 PCI express X 1 adapter slots (2) |
| 17 System fan header | |

Lenovo K410

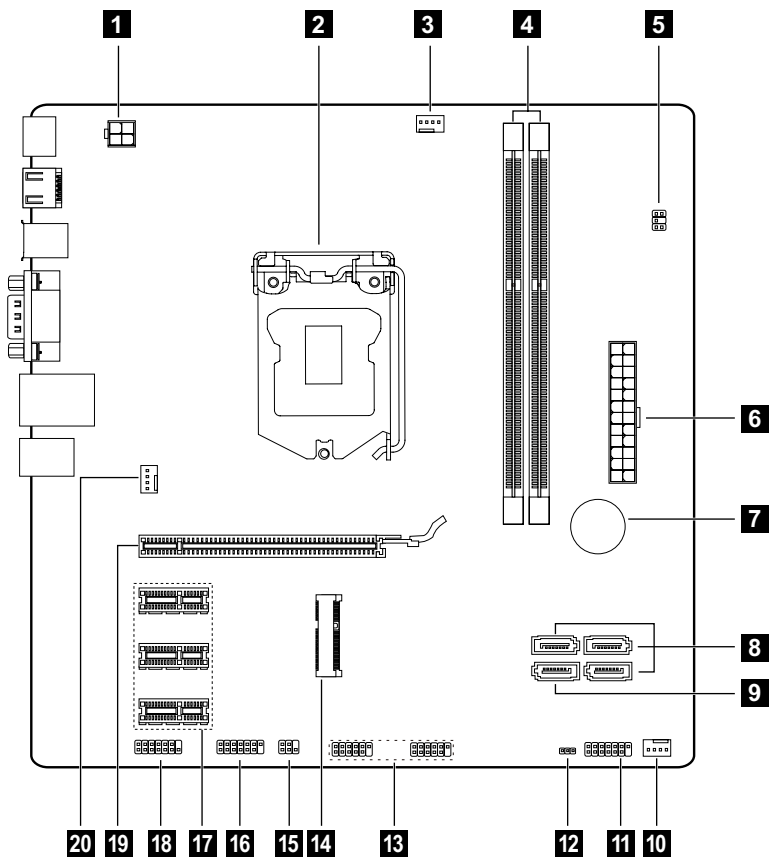

- | | |
|---|---------------------------------------|
| 1 12V power connector | 2 Microprocessor and heat sink |
| 3 Microprocessor fan header | 4 Memory slots (2) |
| 5 Thermal sensor header | 6 Power connector |
| 7 Battery | 8 SATA connectors (3) |
| 9 eSATA connector | 10 Power fan header |
| 11 Front panel connector | 12 Clear CMOS jumper |
| 13 Front USB connectors (2) | 14 Mini PCI-E slot |
| 15 Mode switch connector | 16 Serial (COM2) connector |
| 17 PCI express X 1 adapter slots (3) | 18 Front audio connector |
| 19 PCI express X 16 adapter slot | 20 System fan header |

Lenovo K415

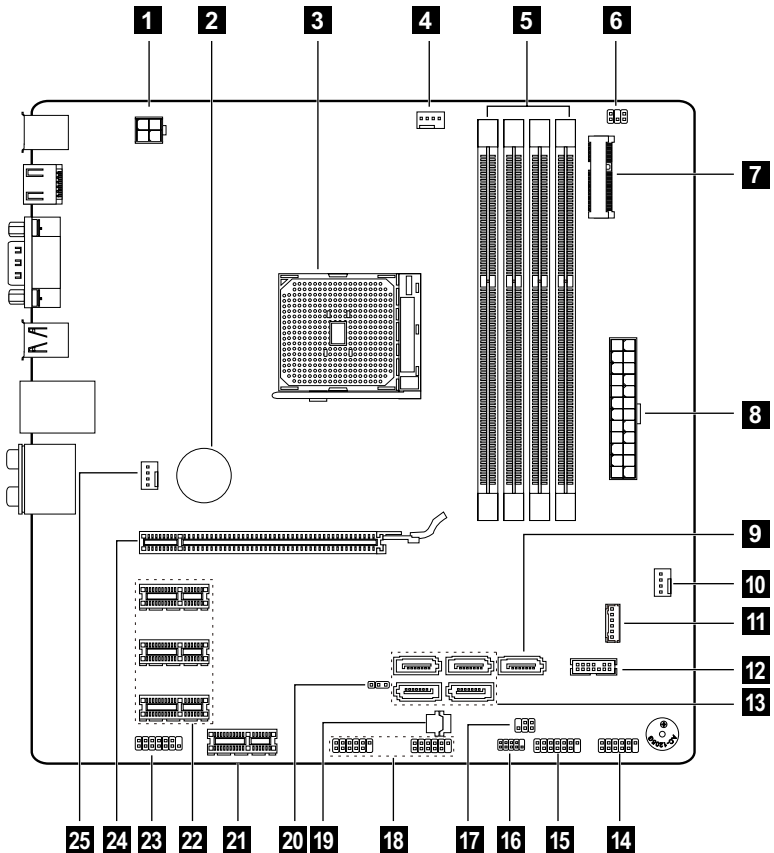

- | | | | |
|-----------|---|-----------|-----------------------------------|
| 1 | 12V power connector | 2 | Battery |
| 3 | Microprocessor and heat sink | 4 | Microprocessor fan header |
| 5 | Memory slots (4) | 6 | Thermal sensor header |
| 7 | Mini PCI-E slot | 8 | Power connector |
| 9 | eSATA connector | 10 | Power fan header |
| 11 | Solid state disk power connector (Optional) | 12 | LPC debug connector |
| 13 | SATA connectors (4) | 14 | Serial (COM2) connector |
| 15 | Front panel connector | 16 | SPI debug connector |
| 17 | Mode switch connector | 18 | Front USB connector (2) |
| 19 | ROM socket | 20 | Clear CMOS jumper |
| 21 | Front USB header | 22 | PCI express X 1 adapter slots (3) |
| 23 | Front audio connector | 24 | PCI express X 16 adapter slot |
| 25 | System fan header | | |

Replacing hardware



Attention: Do not remove the computer cover or attempt any repair before reading the “Important safety information” in the *Safety and Warranty Guide* that was included with your computer or in the *Hardware Maintenance Manual* (HMM) for the computer. To obtain copies of the *Safety and Warranty Guide* or *HMM*, go to the Support Web site at <http://support.lenovo.com>.

General information

Pre-disassembly instructions

Before proceeding with the disassembly procedure, make sure that you do the following:

1. Turn off the power to the system and all peripherals.
2. Unplug all power and signal cables from the computer.
3. Place the system on a flat, stable surface.

Removing the computer cover



Attention:

- Turn off the computer and wait 3 to 5 minutes to let it cool down before removing the cover.
- For this procedure, it helps to lay the computer on a flat, stable surface.

To remove the computer cover:

1. Remove any media (disks, CDs, or memory cards) from the drives, shut down the computer, and turn off all attached devices.
2. Unplug all power cords from electrical outlets.
3. Disconnect all cables attached to the computer. This includes power cords, input/output (I/O) cables, and any other cables that are connected to the computer. Refer to “Locating connectors on the rear of the computer”.
4. Remove the two screws that secure the computer cover at the rear of the chassis.
5. Slide the computer cover out to remove it.

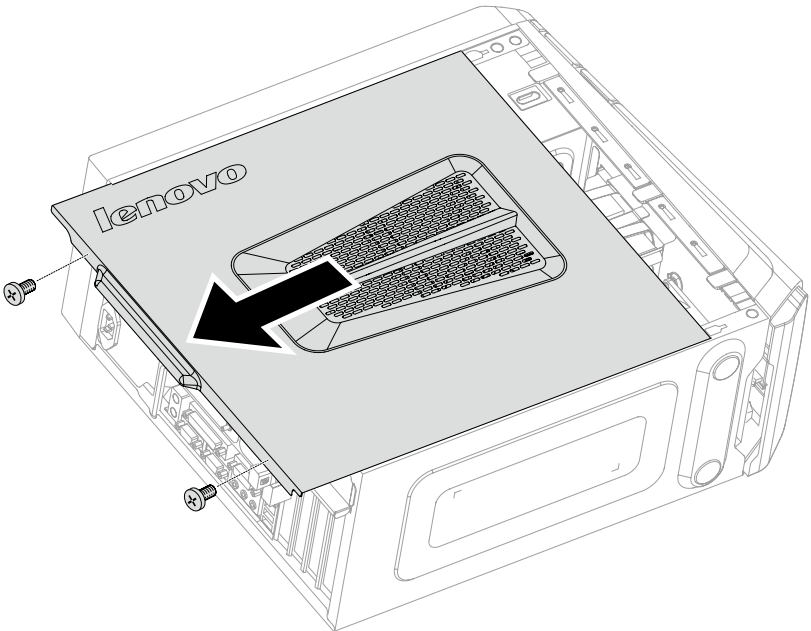

Removing the front bezel

! **Note:** For this procedure, it helps to lay the computer on a flat, stable surface.

To remove the front bezel:

1. Remove the computer cover. Refer to “Removing the computer cover”.
2. Remove the front bezel by releasing the three plastic tabs inside the chassis and sliding the bezel out as shown.

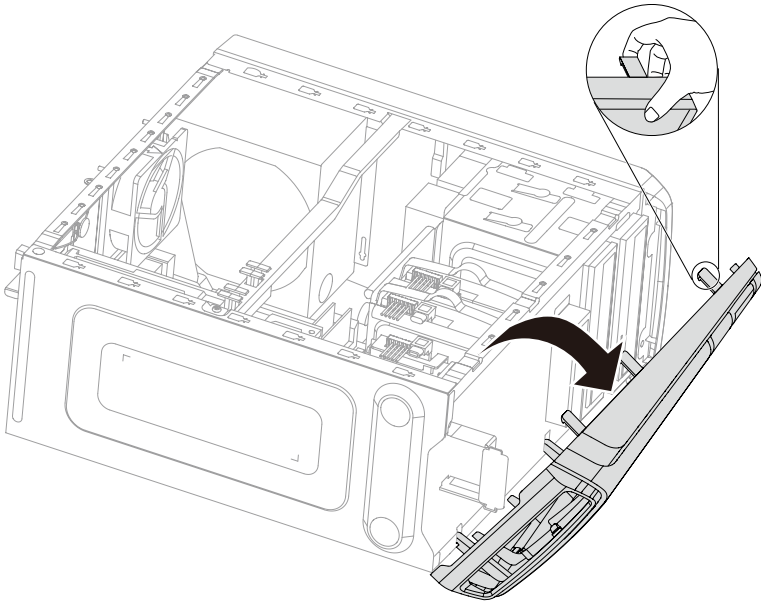

3. To reattach the bezel, align the plastic tabs on the bottom of the bezel with the corresponding holes in the chassis, and then snap it into position.

Replacing a memory module

 **Note:** For this procedure, it helps to lay the computer on a flat, stable surface.

To replace a memory module:

1. Remove the computer cover. Refer to “Removing the computer cover”.
2. Locate the memory module connectors. Refer to “Locating components”.
3. Remove the memory module to be replaced by opening the retaining clips as shown.

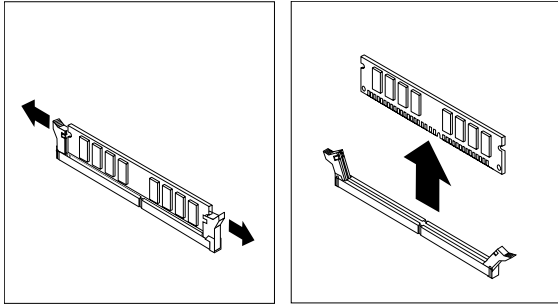

4. Position the new memory module over the memory connector. Make sure that the notch **1** on the memory module aligns correctly with the connector key **2** on the system board. Push the memory module straight down into the connector until the retaining clips close.

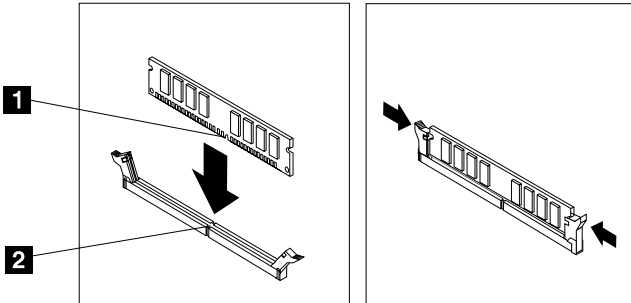

5. Reattach the computer cover.

6. K415 Memory Installation Instructions

! **Note:** The following instructions apply for model K415 only.

Lenovo K415

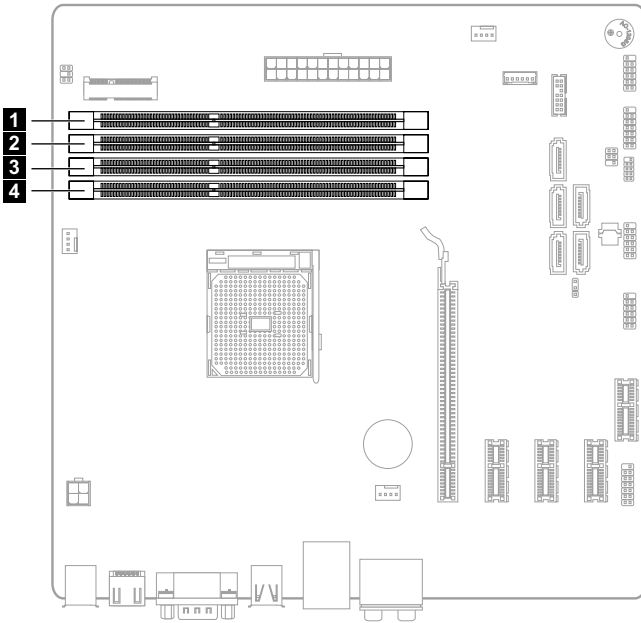

- 1** Slot one
- 3** Slot three

- 2** Slot two
- 4** Slot four

When installing new memory module(s), follow the diagram below to insert the new memory module(s) into different slot(s) depending on how many memory modules are being installed.

Total number of modules	Insert location
One memory module	Slot one or three (1 or 3)
Two memory modules	Slots one and two, three and four or one and three (1 2, 3 4, or 1 3)
Three memory modules	Slots one, two and three or one, three and four (1 2 3 or 1 3 4)
Four memory modules	All slots

Replacing a hard disk drive

! **Note:** For this procedure, it helps to lay the computer on a flat, stable surface.

To replace a hard disk drive:

1. Remove the computer cover. Refer to “Removing the computer cover”.
2. Disconnect the data and power cables from the hard disk drive. **1**
3. Lift up the plastic handle and slide the hard disk drive out of the drive bay. **2**

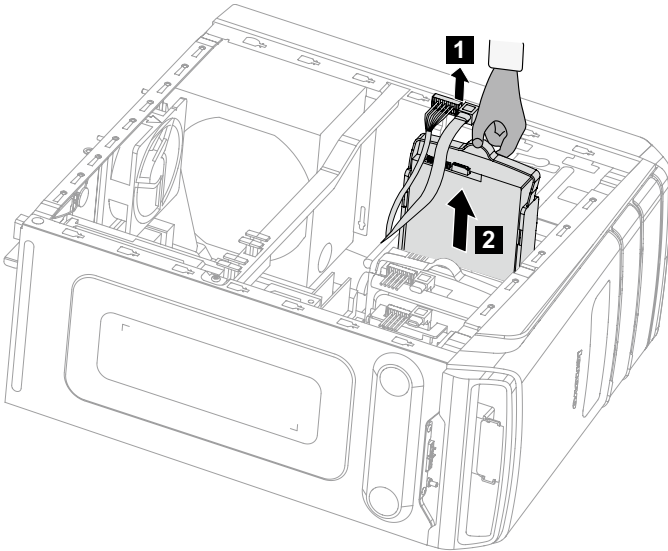

4. Remove the hard disk drive from the plastic bracket as shown.

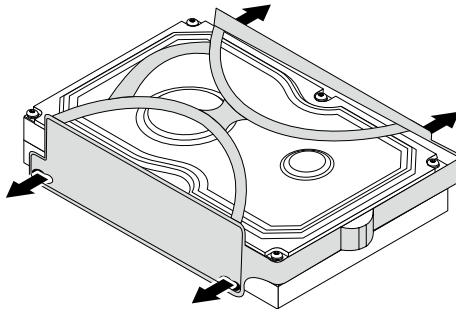

5. Line up the new hard disk drive with the plastic bracket and snap it into position.

6. Slide the new hard disk drive into the drive bay and slide the drive bay into place.
7. Connect the power and signal cables to the new hard disk drive.
8. Reattach the computer cover.

Replacing an optical drive

 **Note:** For this procedure, it helps to lay the computer on a flat, stable surface.

To replace an optical drive:

1. Remove the computer cover. Refer to “Removing the computer cover”.
2. Remove the front bezel. Refer to “Removing the front bezel”.
3. Disconnect the data and power cables from the rear of the optical drive. **1**
4. Press the release button and push the optical drive straight out of the front of the chassis. **2 3**

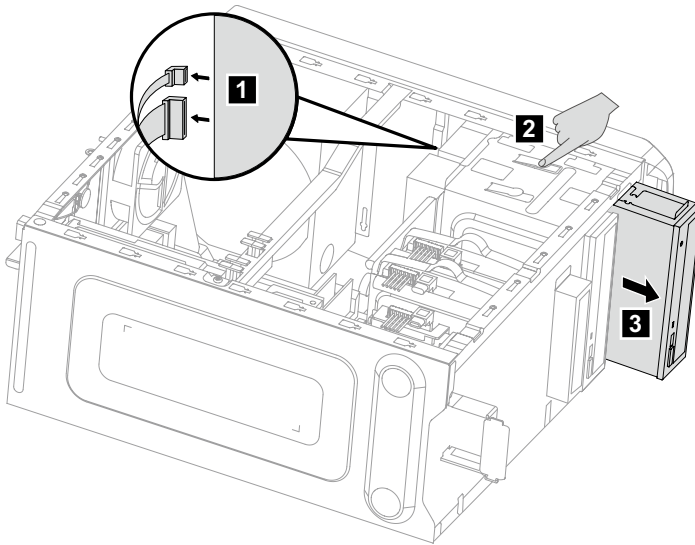

5. Slide the new optical drive into the bay from the front until it snaps into position.
6. Connect the data and power cables to the new disk drive.
7. Reattach the front bezel and computer cover.

Replacing a graphics card

! Note: For this procedure, it helps to lay the computer on a flat, stable surface.

To replace a graphics card:

1. Remove the computer cover. Refer to “Removing the computer cover”.
2. Follow the below steps to remove a graphics card:

If your computer has a Duo-graphics cards installed, follow the steps below to replace it:

- a. Remove the screw that secures the Duo-graphics cards fixing bracket and lift the bracket up.

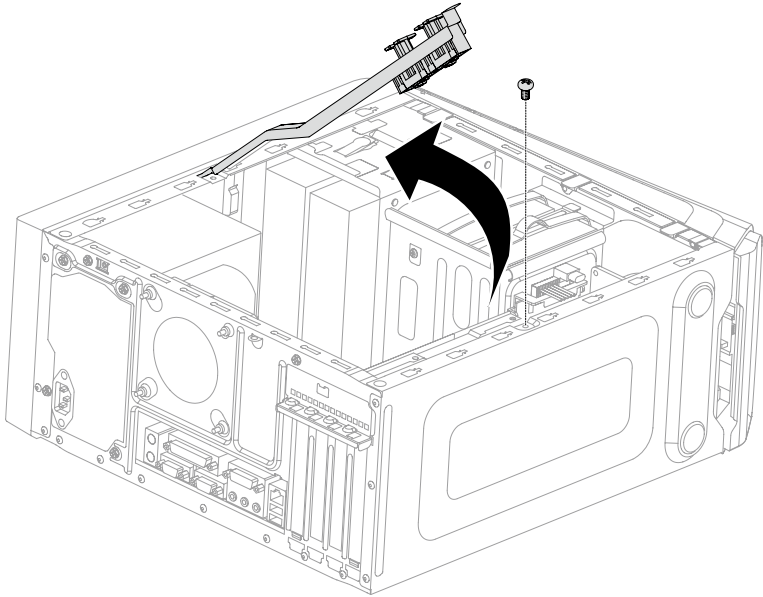

- b. Remove the screw that secures the graphics card latch to the chassis, open it, and remove the Duo-graphics cards connector. **1 2 3**
- c. Remove the screw that secures the graphics card to the chassis. **4**

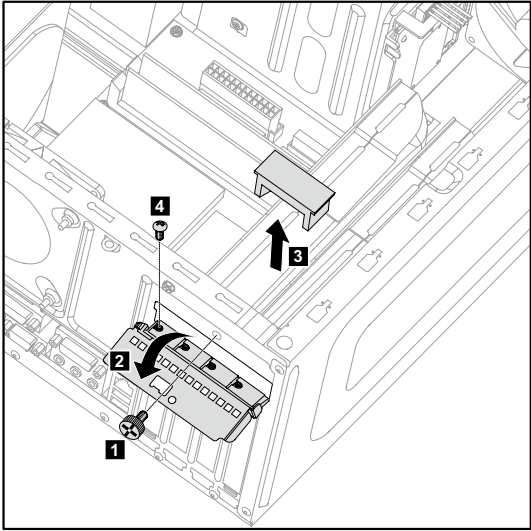

- d. Remove the graphics card by pulling it straight out of the connector.

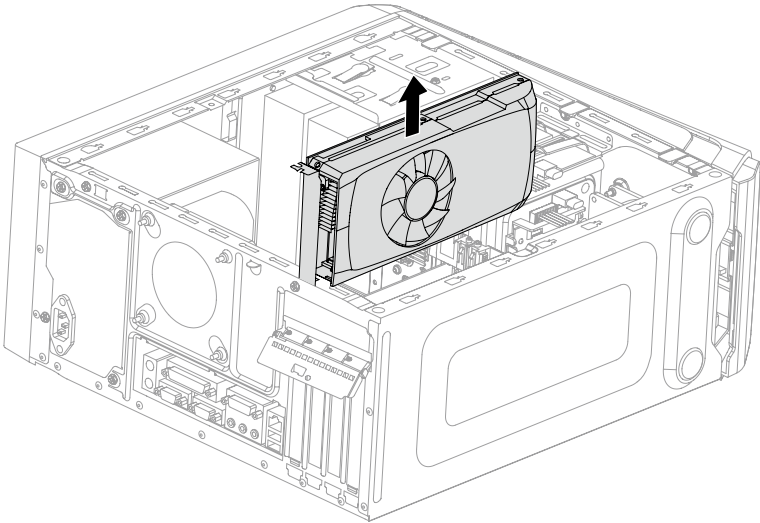

If your computer has a single graphics card installed, follow the steps below to replace it:

- a. Remove the screw that secures the graphics latch to the chassis and open it. **1 2**
- b. Remove the screw that secures the graphics card to the chassis. **3**

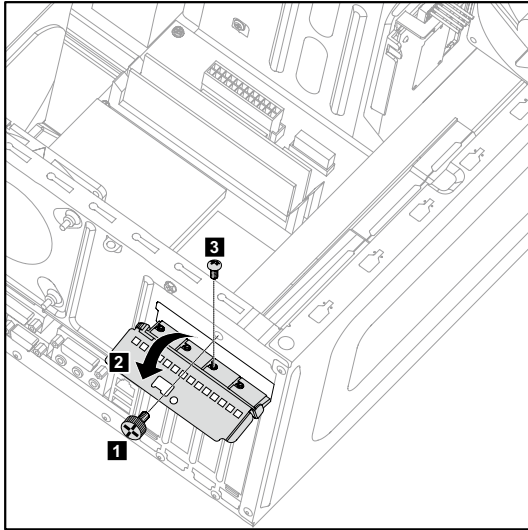

- c. Remove the graphics card by pulling it straight out of the connector.

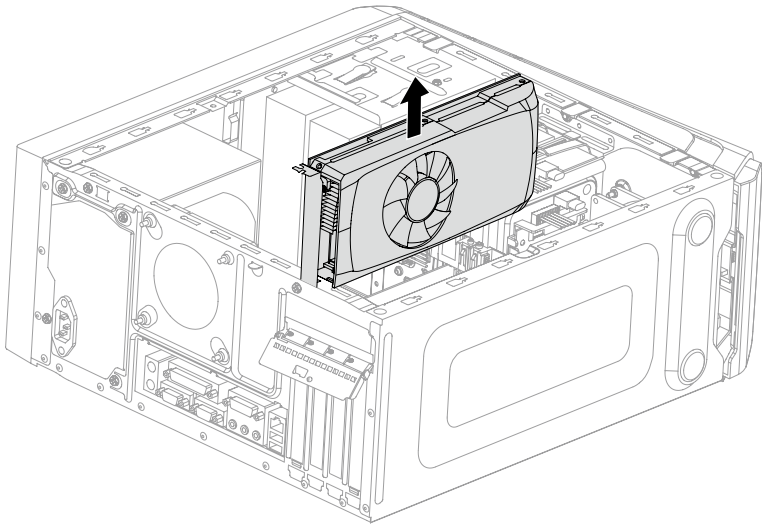

3. Install the new adapter into the same adapter connector and secure it to chassis with the screw.
4. Turn the graphics card latch to the closed position and secure it with the screw.
5. Connect the two graphics cards with the Duo-graphics cards connector and reattach the Duo-graphics cards fixing bracket to the chassis. (For models with Duo-graphics cards only)
6. Reattach the computer cover.

Replacing the TV-Tuner card

! **Note:** For this procedure, it helps to lay the computer on a flat, stable surface.

To replace the TV-Tuner card:

1. Remove the computer cover. Refer to “Removing the computer cover”.
2. Remove the screw that secures the graphics card latch to the chassis and open it. **1 2**
3. Remove the screw that secures the TV-tuner card to the chassis. **3**

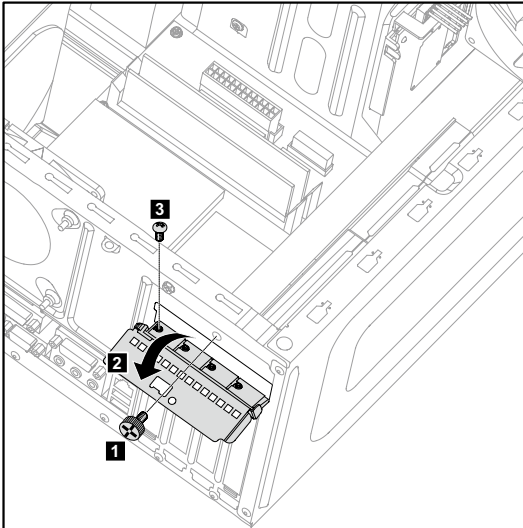

4. Remove the TV-Tuner card by pulling it straight out of the connector.

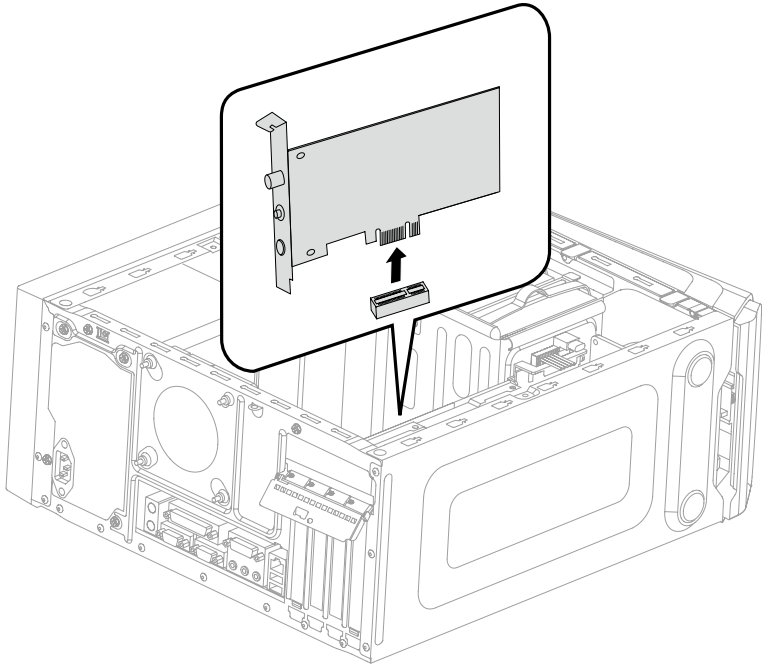

5. Install the new TV-tuner into the same connector and secure it to chassis with the screw.
6. Turn the graphics card latch to the closed position and secure it with the screw.
7. Reattach the computer cover.

Replacing the keyboard and mouse

! **Note:** Your keyboard will be connected to a USB connector at either front or the rear of the computer.

To replace the keyboard:

1. Remove any media (disks, CDs, or memory cards) from the drives, shut down the computer, and turn off all attached devices.
2. Unplug all power cords from electrical outlets.
3. Locate the connector for the keyboard. Refer to “Front view of the chassis” and “Rear view of the chassis”.

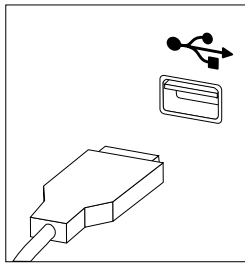

4. Disconnect the defective keyboard cable from the computer and connect the new keyboard cable to the same connector.

* **The mouse can be replaced using the same method.**

Appendix.

Declaration

Thank you for using Lenovo products.

Carefully read all documents shipped with your computer before you install and use the product for the first time. Lenovo is not responsible for any loss except when caused by installation and operations performed by Lenovo professional service personnel. You are responsible if you fail to operate the product according to instructions and requirements in the manuals included with your computer, or operate the product inappropriately.

This manual could include technical inaccuracies or typographical errors. Changes are made periodically to the information herein; these changes will be incorporated in new editions of the publication. To provide better service, Lenovo reserves the right to improve and/or modify the products and software programs described in the manuals included with your computer, and the content of the manual, at any time without additional notice.

The manuals included with your computer are provided to help you use Lenovo's products appropriately. For the configuration of the product, refer to the related contract (if any) or product packing list, or consult the distributor for the product sales.

The content of the manuals included with your computer is protected by copyright laws and rules. None of the manuals included with your computer may be reproduced or transcribed by any means or translated into any language without prior written permission of Lenovo.

The software interface and function and hardware configuration described in the manuals included with your computer might not match exactly the actual configuration of the computer that you purchase. You are welcome to contact us about the manuals included with your computer. For the latest information or any questions or comments, contact or visit the Lenovo Web site:

Service Web site: <http://support.lenovo.com>

Trademarks

Lenovo and the Lenovo logo, IdeaCentre and IdeaCentre logo are trademarks of Lenovo in the United States, other countries, or both.

Microsoft, Windows, and Windows Vista are trademarks of the Microsoft group of companies.

Intel Inside is a trademark of Intel Corporation in the U.S. and/or other countries.

AMD, the AMD Arrow logo, ATI, AMD Athlon, AMD LIVE!, AMD Opteron, AMD Phenom, AMD Sempron, Catalyst, Cool 'n' Quiet, CrossFire, PowerPlay, Radeon, and The Ultimate Visual Experience are trademarks of Advanced Micro Devices, Inc.

Other company, product, or service names referred to herein or in other Lenovo publications may be trademarks or service marks of others.

All rights reserved.

Names or marks of certain companies mentioned in the manuals included with your computer or this document do not necessarily indicate that related software or hardware is included. The actual configuration of the product depends on the packing list description.

Energy Star Statement



ENERGY STAR® is a joint program of the U.S. Environmental Protection Agency and the U.S. Department of Energy aimed at saving money and protecting the environment through energy efficient products and practices.

Lenovo is proud to offer our customers products with an ENERGY STAR compliant designation. The following machine types have been designed and tested to conform to the ENERGY STAR program requirement for computers at the time of manufacture. For more information about ENERGY STAR ratings for Lenovo computers, go to <http://www.lenovo.com>.

- 4744
- 4748
- 4743
- 10121/90A1

By using ENERGY STAR compliant products and taking advantage of the power-management features of your computer, you reduce the consumption of electricity. Reduced electrical consumption contributes to potential financial savings, a cleaner environment, and the reduction of greenhouse gas emissions.

For more information about ENERGY STAR, go to: <http://www.energystar.gov>.

Lenovo encourages you to make efficient use of energy an integral part of your day-to-day operations. To help in this endeavor, Lenovo has preset the following power-management features to take effect when your computer has been inactive for a specified duration:

ENERGY STAR power-management features, by operating system.

Microsoft Windows Vista, Windows 7 and Windows 8

Power plan: Balanced

- Turn off the display: After 10 minutes
- Put the computer to sleep: After 25 minutes
- Advanced power settings:
 - Turn off hard disk drives: After 20 minutes
 - Hibernate: Never

To awaken your computer from a Sleep or System Standby mode, press any key on your keyboard. For more information about these settings, refer to your Windows Help and Support information system.

Enabling ErP compliance mode

You can enable the energy-related products directive (ErP) compliance mode through the **Power** menu in the Setup Utility program. This mode reduces electricity consumption when your computer is in standby mode or turned off.

To enable ErP compliance mode in the Setup Utility program, do the following:

1. Repeatedly press and release the F1 key when turning on the computer to start the Setup Utility program.
2. From the Setup Utility program main menu, select **Power** → **ErP** and press Enter.
3. Select **Enabled** and press Enter.
4. Press F10 to save changes and exit the Setup Utility program. Press Enter when prompted to confirm.

 **Note:** When ErP compliance mode is enabled, you only can wake up your computer by pressing the power switch.